

100/150 Series Camclosure® Camera System

MINI DOME, SURFACE AND IN-CEILING

Product Features

- Fully-Integrated Enclosure with Camera and Lens
- Rugged, High-Impact, Vandal-Resistant, Puncture-Proof Domes; Tamper-Resistant Hardware
- Available with DSS LowLight™ Technology
- Easy to Install; Camera Module Easy to Remove
- Versatile Models for Surface or In-Ceiling Mounting
- 12 VDC or 24 VAC Operation
- Low-Temperature Operation to -50°F (-46°C); De-ices to 25°F (-4°C)
- Available with Smoked or Clear Dome
- NTSC/PAL or EIA/CCIR Camera Formats
- All Color Cameras Feature Digital Signal Processing



ICS100 SERIES DOME



ICS150 SERIES DOME

The **100/150 Series Camclosure® Integrated Camera System** integrates a camera and lens package into a small, high-security enclosure. All models are quick and easy to install and are perfect for a variety of indoor and outdoor applications. It is ideal for residential, office, mall, hospital, school, parking garage, correction and detention, and other medium-security installations subject to vandalism.

The **100 Series System** surface-mount dome is designed to mount directly to a ceiling, wall, or 4S electrical box using an optional adapter plate or standard mud ring. The dome's back box features two conduit openings, one in the back, and a threaded 3/4-inch opening in the side.

The **150 Series System** is an in-ceiling dome designed for suspended ceiling or recessed ceiling/wall installations. An adapter plate is supplied with the dome to mount the unit to a 4S electrical box or to provide additional support for suspended ceiling installations.

The lower dome of the **100/150 Series System** is available with clear or smoked bubble. Models with a clear lower dome include a black dome liner for discreet viewing. Domes with a smoked bubble may be purchased without the camera module for pre-installation or for camera bicycling.

The **100/150 Series Camclosure System** offers a large selection of camera and lens options. Available camera modules include the following:

- LowLight™ DSS, high-resolution color camera with auto iris, varifocal lens (2.6-6 mm or 4-9 mm)
- High-resolution color camera with auto iris, varifocal lens (3-6 mm or 4-9 mm)
- High and standard resolution color cameras with fixed focal length lenses (without or with iris)
- Standard resolution monochrome cameras with fixed focal length lenses

The LowLight™ color camera has extended Digital Slow Shutter (DSS) settings to enhance the low light performance of the camera by automatically adjusting the number of fields of integration. This slows the picture frame rate and increases the camera's sensitivity in low light conditions.

All color cameras with fixed focal length lenses are available with or without auto iris, and the monochrome camera is available with a fixed focal lens without auto iris. Available fixed auto iris lenses include 6 mm, 8 mm, or 12 mm.



DataFAX
SPEC: 22407
MANUAL: 224076
C2407 / REVISED 7-03



TECHNICAL SPECIFICATIONS

GENERAL

Construction	Aluminum with steel camera mounting bracket and polycarbonate dome
Finish	
ICS100 Series	Light gray polyester powder coat
ICS150 Series	White polyester powder coat trim ring with charcoal gray back box
Light Attenuation	
Smoked	1.5 f-stops light loss
Clear	Zero light loss
Dimensions	
ICS100 Series	
Base	3.70 (H) x 5.30 (W) inches (9.40 x 13.46 cm)
Bubble	3.75 inch Diameter
ICS150 Series	
Above Ceiling	1.75 (H) x 3.50 (W) inches (4.45 x 8.89 cm)
Below Ceiling	2.42 (H) x 5.48 (W) inches (6.15 x 13.90 cm)
Bubble	3.75 inch Diameter
Unit Weight	
ICS100 Series	2.20 lb (1.00 kg)
ICS150 Series	1.70 lb (0.77 kg)
Shipping Weight	
ICS100 Series	4.0 lb (1.81 kg)
ICS150 Series	3.0 lb (1.36 kg)

ELECTRICAL

Input Voltage*	12 VDC or 24 VAC ($\pm 10\%$)
Power Consumption	
Camera	<3 watts
Heaters	10 watts when active; thermostatically controlled

MECHANICAL

Cable Entry	
ICS100 Series	One 3/4-inch (1.91 cm) NPT threaded opening on side; one 3/4-inch (1.91 cm) opening on base
Pan/Tilt Adjustment	Manual 360° pan; 180° tilt

VIDEO

Signal System	
Monochrome	EIA or CCIR
Color	NTSC or PAL
Video Connector	BNC
Scanning System	2:1 interlace
Video Out	1 Vp-p Composite (75 ohm)

ENVIRONMENTAL

Environment	Low temperature, indoor/outdoor
Operating Temperature	-50°F to 122°F (-46°C to 50°C); de-ices to 25°F (-4°C)
Thermostat Operation	Heater is thermostatically controlled to activate ON at 50°F (10°C) and OFF at 80°F (27°C)

CERTIFICATIONS/RATINGS

- CE and FCC, Class A (models with monochrome cameras only, excluding auto iris models)
- CE and FCC, Class B (models with color cameras only, excluding auto iris models)
- UL Listed
- UL Listed to Canadian safety standards
- Meets NEC requirements for use in environmental air handling spaces.
- Tested in accordance with MIL-STD 810E as follows:
 - Shock test; Section 516.4 (exceeds IEC 68-2-27)
 - Humidity test; Sections 520.1 and 507.3 (exceeds IEC 68-2-30)
 - Vibration test; Section 514.4 (exceeds IEC 68-2-6)
- ASTM Shipping Standard
- ISTA Shipping Standard

All tests are performed in accordance with ISO Guide 25 and ANSI/NCSL Z540-1.

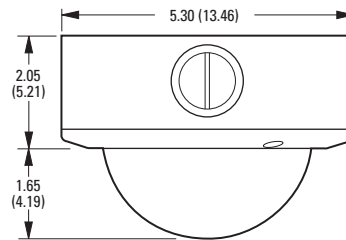

NOTE: VALUES IN PARENTHESES ARE CENTIMETERS; ALL OTHERS ARE INCHES.

ICS100 SERIES DOME

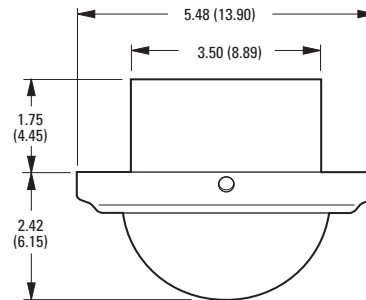

NOTE: VALUES IN PARENTHESES ARE CENTIMETERS; ALL OTHERS ARE INCHES.

ICS150 SERIES DOME

*24 VAC power is recommended when installing any Camclosure® Integrated Camera System under fluorescent lighting conditions.

TECHNICAL SPECIFICATIONS

CAMERA SPECIFICATIONS

Color, High Resolution

	Color High Resolution Fixed, Without Iris (Models ICSxxx-CR _x /ICSxxx-CS _x)	Color High Resolution Fixed, Auto Iris (Models ICSxxx-CR _x A/ICSxxx-CS _x A)	Color High Resolution Varifocal, Auto Iris (Models ICSxxx-CRV _x A/ICSxxx-CSV _x A)	LowLight DSS Color Varifocal, Auto Iris (Models ICSxxx-CDV _x A/ICSxxx-CEV _x A)
Imaging Device	1/3-inch Interline Color CCD (Super HAD™)	1/3-inch Interline Color CCD (Super HAD™)	1/4-inch Interline Color CCD (Super HAD™)	1/3-inch Interline Color CCD
Sync System	12 VDC: Internal 24 VAC: External (VD Lock)	12 VDC: Internal 24 VAC: External (VD Lock)	12 VDC: Internal 24 VAC: External (VD Lock)	Adjustable AC line lock/internal, auto select
Horizontal Resolution	NTSC: 470 TV lines PAL: 460 TV lines	NTSC: 450 TV lines PAL: 440 TV lines	NTSC: 480 TV lines PAL: 480 TV lines	NTSC: 480 TV lines PAL: 480 TV lines
Signal-to-Noise Ratio	48 dB	48 dB	48 dB (AGC Off)	50 dB
Min. Illumination	1 lux (f2.0)	1 lux (f2.0)	Less than 1.2 lux (f1.2)	.075 lux @ 40 IRE DSS Off, F1.6 @ wide angle 1.20 lux @ 50 IRE DSS Off, F1.6 @ wide angle 0.025 lux @ 40 IRE, 30 fields of DSS, F1.6 @ wide angle 0.040 lux @ 50 IRE, 30 fields of DSS, F1.6 @ wide angle
Gain Control	NTSC: Auto PAL: Manual	Auto	On/Off by DIP switch (0-20dB)	Auto/Manual by DIP switch
Exposure	Electronic Shutter (1/60 - 1/100,000)	Automatic Control w/DC Iris Meter (1/60 - 1/100,000)	Electronic Shutter (1/60 - 1/100,000)	Automatic Control w/DC Iris Meter (1/60 - 1/100,000)
White Balance	Auto	Auto	Auto or manual (switch selectable)	Auto
Backlight Compensation	Auto or manual (switch selectable)	Auto or manual (switch selectable)	Auto; adjusts AGC and AES	ON/OFF (switch selectable)

B&W and Color, Standard Resolution

	Black & White Standard Resolution Fixed, Without Iris (Models ICSxxx-MA _x /ICSxxx-MC _x)	Color Standard Resolution Fixed, Without Iris (Models ICSxxx-CA _x /ICSxxx-CC _x)	Color Standard Resolution Fixed, Auto Iris (Models ICSxxx-CA _x A/ICSxxx-CC _x A)
Imaging Device	1/3-inch CCD	1/3-inch Interline Color CCD	1/3-inch Interline Color CCD (Super HAD™)
Sync System	Internal	12 VDC: Internal 24 VAC: External (VD Lock)	12 VDC: Internal 24 VAC: External (VD Lock)
Horizontal Resolution	EIA: 420 TV lines CCIR: 420 TV lines	NTSC: 350 TV lines PAL: 350 TV lines	NTSC: 330 TV lines PAL: 320 TV lines
Signal-to-Noise Ratio	50 dB	48 dB	48 dB
Min. Illumination	0.1 lux (f2.0)	1 lux (f2.0)	1 lux (f2.0)
Gain Control	Auto	Auto	Auto
Exposure	Electronic Shutter (1/60 - 1/100,000)	Electronic Shutter (1/60 - 1/100,000)	Automatic Control w/DC Iris Meter (1/60 - 1/100,000)
White Balance	(not applicable)	Auto	Auto
Backlight Compensation	Auto	Auto or manual (switch selectable)	Auto or manual (switch selectable)

LENS SPECIFICATIONS

Camera	Fixed Focal Without Iris									
	Color	B/W	Color	B/W	Color	B/W	Color	B/W	Color	B/W
Focal Length	2.9 mm	3.0 mm	3.6 mm		6.0 mm		8.0 mm		12.0 mm	
Format Size	1/3-inch		1/3-inch		1/3-inch		1/3-inch		1/3-inch	
Relative Aperture (F)	2.0		2.0		1.8	2.5	1.8	2.5	2.0	
Operation	N/A		N/A		N/A		N/A		N/A	
Iris	Manual		Manual		Manual		Manual		Manual	
Focus	N/A		N/A		N/A		N/A		N/A	
Zoom	N/A		N/A		N/A		N/A		N/A	
Angle of View**	90°		87°		74°		42°	38°	32°	29°
Horizontal	—		—		—		—		—	
Diagonal	69°		67°		55°		33°	30°	25°	23°
Vertical	—		—		—		—		—	

Camera	Fixed Focal With Auto Iris		
	Color	Color	Color
Focal Length	6.0 mm	8.0 mm	12.0 mm
Format Size	1/3-inch	1/3-inch	1/3-inch
Relative Aperture (F)	1.8	1.8	1.8
Operation	Auto	Auto	Auto
Iris	Manual	Manual	Manual
Focus	N/A	N/A	N/A
Zoom	N/A	N/A	N/A
Angle of View**	42°		
Horizontal	32°		
Diagonal	21°		
Vertical	33°	25°	17°

Camera	Varifocal With Auto Iris			
	LowLight DSS Color High Resolution		Color High Resolution	
Focal Length	2.6 mm ~ 6.0 mm		4.0 mm ~ 9.0 mm	
Format Size	1/3-inch		1/4-inch	
Relative Aperture (F)	1.6		1.2 to 1.5	
Operation	Auto		Auto	
Iris	Manual		Manual	
Focus	Manual		Manual	
Zoom	Manual		Manual	
Angle of View**	106.0° to 47.6°		71.6° to 31.6°	
Horizontal	134.8° to 59.4°		92.6° to 39.4°	
Diagonal	78.2° to 35.8°		51.8° to 23.6°	
Vertical	—		—	

**Focal length specifications presume a 10% horizontal and 4% vertical monitor overscan.

SYSTEM MODELS AND ACCESSORIES

MODELS

Dome Only

The following models allow pre-installation of domes or can be used in a camera bicycling installation:

ICS-DO100A	ICS100 Series surface mount dome (no camera/lens) with smoked bubble.
ICS-DO150A	ICS150 Series in-ceiling dome (no camera/lens) with smoked bubble.

SYSTEM MODELS, B&W Camera

Camera Type	Lower Dome	Lens	Lens Type	Surface Mount (ICS100 Series)		In-Ceiling (ICS150 Series)	
				EIA	CCIR	EIA	CCIR
B&W, Standard Resolution	Smoked	3.0 mm	Fixed, without iris	ICS100-MA3	ICS100-MC3	ICS150-MA3	ICS150-MC3
		3.6 mm	Fixed, without iris	ICS100-MA3.6	ICS100-MC3.6	ICS150-MA3.6	ICS150-MC3.6
		6 mm	Fixed, without iris	ICS100-MA6	ICS100-MC6	ICS150-MA6	ICS150-MC6
		8 mm	Fixed, without iris	ICS100-MA8	ICS100-MC8	ICS150-MA8	ICS150-MC8
		12 mm	Fixed, without iris	ICS100-MA12	ICS100-MC12	ICS150-MA12	ICS150-MC12
	Clear	3.0 mm	Fixed, without iris	ICS101-MA3	ICS101-MC3	ICS151-MA3	ICS151-MC3
		3.6 mm	Fixed, without iris	ICS101-MA3.6	ICS101-MC3.6	ICS151-MA3.6	ICS151-MC3.6
		6 mm	Fixed, without iris	ICS101-MA6	ICS101-MC6	ICS151-MA6	ICS151-MC6
		8 mm	Fixed, without iris	ICS101-MA8	ICS101-MC8	ICS151-MA8	ICS151-MC8
		12 mm	Fixed, without iris	ICS101-MA12	ICS101-MC12	ICS151-MA12	ICS151-MC12

SYSTEMS MODELS, Color Camera

Camera Type	Lower Dome	Lens	Lens Type	Surface Mount (ICS100 Series)		In-Ceiling (ICS150 Series)	
				NTSC	PAL	NTSC	PAL
DSS Color, High Resolution	Smoked	2.6 ~ 6 mm	Varifocal, auto iris	ICS100-CDV3A	ICS100-CEV3A	ICS150-CDV3A	ICS150-CEV3A
		4 ~ 9 mm	Varifocal, auto iris	ICS100-CDV4A	ICS100-CEV4A	ICS150-CDV4A	ICS150-CEV4A
	Clear	2.6 ~ 6 mm	Varifocal, auto iris	ICS101-CDV3A	ICS101-CEV3A	ICS151-CDV3A	ICS151-CEV3A
		4 ~ 9 mm	Varifocal, auto iris	ICS101-CDV4A	ICS101-CEV4A	ICS151-CDV4A	ICS151-CEV4A
Color, High Resolution	Smoked	2.9 mm	Fixed, without iris	ICS100-CR3	ICS100-CS3	ICS150-CR3	ICS150-CS3
		3.6 mm	Fixed, without iris	ICS100-CR3.6	ICS100-CS3.6	ICS150-CR3.6	ICS150-CS3.6
		6 mm	Fixed, without iris	ICS100-CR6	ICS100-CS6	ICS150-CR6	ICS150-CS6
			Fixed, auto iris	ICS100-CR6A	ICS100-CS6A	ICS150-CR6A	ICS150-CS6A
		8 mm	Fixed, without iris	ICS100-CR8	ICS100-CS8	ICS150-CR8	ICS150-CS8
			Fixed, auto iris	ICS100-CR8A	ICS100-CS8A	ICS150-CR8A	ICS150-CS8A
		12 mm	Fixed, without iris	ICS100-CR12	ICS100-CS12	ICS150-CR12	ICS150-CS12
			Fixed, auto iris	ICS100-CR12A	ICS100-CS12A	ICS150-CR12A	ICS150-CS12A
	Clear	3 ~ 6 mm	Varifocal, auto iris	ICS100-CRV3A	ICS100-CSV3A	ICS150-CRV3A	ICS150-CSV3A
		4 ~ 9 mm	Varifocal, auto iris	ICS100-CRV4A	ICS100-CSV4A	ICS150-CRV4A	ICS150-CSV4A
		2.9 mm	Fixed, without iris	ICS101-CR3	ICS101-CS3	ICS151-CR3	ICS151-CS3
		3.6 mm	Fixed, without iris	ICS101-CR3.6	ICS101-CS3.6	ICS151-CR3.6	ICS151-CS3.6
		6 mm	Fixed, without iris	ICS101-CR6	ICS101-CS6	ICS151-CR6	ICS151-CS6
			Fixed, auto iris	ICS101-CR6A	ICS101-CS6A	ICS151-CR6A	ICS151-CS6A
		8 mm	Fixed, without iris	ICS101-CR8	ICS101-CS8	ICS151-CR8	ICS151-CS8
			Fixed, auto iris	ICS101-CR8A	ICS101-CS8A	ICS151-CR8A	ICS151-CS8A
12 mm	Fixed, without iris	ICS101-CR12	ICS101-CS12	ICS151-CR12	ICS151-CS12		
	Fixed, auto iris	ICS101-CR12A	ICS101-CS12A	ICS151-CR12A	ICS151-CS12A		
	3 ~ 6 mm	Varifocal, auto iris	ICS101-CRV3A	ICS101-CSV3A	ICS151-CRV3A	ICS151-CSV3A	
	4 ~ 9 mm	Varifocal, auto iris	ICS101-CRV4A	ICS101-CSV4A	ICS151-CRV4A	ICS151-CSV4A	

SYSTEM MODELS AND ACCESSORIES

SYSTEMS MODELS, Color Camera

Camera Type	Lower Dome	Lens	Lens Type	Surface Mount (ICS100 Series)		In-Ceiling (ICS150 Series)	
				NTSC	PAL	NTSC	PAL
Color, Standard Resolution	Smoked	2.9 mm	Fixed, without iris	ICS100-CA3	ICS100-CC3	ICS150-CA3	ICS150-CC3
		3.6 mm	Fixed, without iris	ICS100-CA3.6	ICS100-CC3.6	ICS150-CA3.6	ICS150-CC3.6
		6 mm	Fixed, without iris	ICS100-CA6	ICS100-CC6	ICS150-CA6	ICS150-CC6
			Fixed, auto iris	ICS100-CA6A	ICS100-CC6A	ICS150-CA6A	ICS150-CC6A
		8 mm	Fixed, without iris	ICS100-CA8	ICS100-CC8	ICS150-CA8	ICS150-CC8
			Fixed, auto iris	ICS100-CA8A	ICS100-CC8A	ICS150-CA8A	ICS150-CC8A
		12 mm	Fixed, without iris	ICS100-CA12	ICS100-CC12	ICS150-CA12	ICS150-CC12
		Fixed, auto iris	ICS100-CA12A	ICS100-CC12A	ICS150-CA12A	ICS150-CC12A	
	Clear	2.9 mm	Fixed, without iris	ICS101-CA3	ICS101-CC3	ICS151-CA3	ICS151-CC3
		3.6 mm	Fixed, without iris	ICS101-CA3.6	ICS101-CC3.6	ICS151-CA3.6	ICS151-CC3.6
		6 mm	Fixed, without iris	ICS101-CA6	ICS101-CC6	ICS151-CA6	ICS151-CC6
			Fixed, auto iris	ICS101-CA6A	ICS101-CC6A	ICS151-CA6A	ICS151-CC6A
		8 mm	Fixed, without iris	ICS101-CA8	ICS101-CC8	ICS151-CA8	ICS151-CC8
			Fixed, auto iris	ICS101-CA8A	ICS101-CC8A	ICS151-CA8A	ICS151-CC8A
12 mm		Fixed, without iris	ICS101-CA12	ICS101-CC12	ICS151-CA12	ICS151-CC12	
	Fixed, auto iris	ICS101-CA12A	ICS101-CC12A	ICS151-CA12A	ICS151-CC12A		

LENS PACK OPTIONS

Lens packs offer the added convenience of easily changing a camera's field of view by simply changing the lens.

All fixed focal length lenses without iris (2.9 mm to 12 mm) are interchangeable with any camera module. Fixed focal length auto iris and varifocal lenses are not interchangeable.

Variety Pack*

13FFD-V5PAK Variety package of five lenses, one each 2.9 mm, 3.6 mm, 6 mm, 8 mm, and 12 mm

Single Lens Pack*

13FF3D 2.9 mm lens and mount
 13FF3.6D 3.6 mm lens and mount
 13FF6D 6 mm lens and mount
 13FF8D 8 mm lens and mount
 13FF12D 12 mm lens and mount

Four Lens Pack*

13FF3D-4PAK Package of four 2.9 mm lenses and mounts
 13FF3.6D-4PAK Package of four 3.6 mm lenses and mounts
 13FF6D-4PAK Package of four 6 mm lenses and mounts

*Fixed focal length lenses, without auto iris.

RECOMMENDED POWER SUPPLIES

(For use with 24 VAC models only)

TF2000

Power supply for 24 VAC cameras, 20 vA.
(For single camera application.)

MCS Series
 MCS*E Series
 WCS Series

Multiple 24 VAC camera power supply, indoor.
 Multiple 24 VAC camera power supply, indoor.
 Single/Multiple 24 VAC camera power supply, outdoor.

OPTIONAL MOUNTS

ICS100-AP

Adapter plate for a 4-square electrical box. (ICS100 Series only)

ICS100-PG

Pendant mount adapter for ICS100 Series dome. Must be used with SWM-GY mount, or BB5-PCA-GY and conduit.

ICS150-P

2 x 2 ft (61 x 61 cm) metal ceiling panel for ICS150 Series in-ceiling dome.



**ICS100-PG SHOWN WITH
 ICS100 DOME AND
 SWM-GY MOUNT**



Pelco Worldwide Headquarters:

3500 Pelco Way, Clovis, California 93612-5699 USA
USA & Canada Tel: (800) 289-9100 • FAX (800) 289-9150 • DataFAX (800) 289-9108
International Tel: (559) 292-1981 • FAX (559) 348-1120 • DataFAX (559) 292-0435
www.pelco.com

Super HAD™ is a trademark of the Sony Corporation.
 LowLight™ is a trademark of Pelco.
 Camclosure® is a registered trademark of Pelco.
 Specifications subject to change without notice.
 ©Copyright 2003, Pelco. All rights reserved.